



# DATA SHEET

## 4S1200E

***Removes Contaminants***

***Extends Oil Life***

***Reduces Component Wear***

***Removes all Water***

***Saves Machine Downtime***

***Reduces Disposal Costs***

***Simple to Install & Use***

***Low Maintenance Costs***

***Built in Sampling Points***



Cardev International Ltd

Ripon Way, Harrogate, HG1 2AU  
Tel: 01423 522911 Fax: 01423 530043  
Email: sales@cardev.co.uk or visit our  
website at: www.cardev.co.uk



# Cardev International Ltd

Ripon Way, Harrogate, HG1 2AU Tel: 01423 522911 Fax: 01423 530043  
 e-mail: sales@cardev.co.uk web: www.cardev.co.uk



Industrial Filtration



Biodegradable Lubricants

4S1200E - SPECIFICATION				
Electric Motor	VOLTS	110	230	
	Kws	0.37	0.37	
	Amps	8.0	4.0	
	RPM	1425	1425	
	Protection	IP65		
Pump Performance	1200 litres/hour @ 2.6 bar (ISO 46 Hydraulic oil at 40°C) 1600 litres/hr @ 1 bar—transfer rate using valve			
Pump Suction Lift	Self priming to 5.5 metres			
Operating Temperature	10-90°C			
Rig Dimensions	Length	950 mm		
	Width	595 mm		
	Height	1000 mm		
	(with handle removed)	780 mm		
Rig Weight	103 kg			
Filtration System	4 x SDUFB-C			
Cartridge Type	4 x SDFC—Fitted as standard. Supplied in boxes of 6			
Accessories	6 metres of reinforced 1" hose with quick release couplings Fitted with outlet/transfer control valve, Plug to suit voltage (UK only)			
Options	110v, 3-phase and air motors 45 cm Bag Pre-filter, Particle Counter, Flow meter SDFC-P Cartridges for water based fluids			

FLT1	MAIN FILTERS (SDU/SDFC)
FLT2	PRE-FILTER
M1	PUMP MOTOR
V1	PRESSURE CONTROL VALVE
Q1	CONTROL UNIT
PG1	PRESSURE GAUGE
PS1	PRESSURE SWITCH
QRC1	INLET QUICK RELEASE COUPLING
QRC2	OUTLET QUICK RELEASE COUPLING
SP1	HIGH PRESSURE SAMPLE POINT
SP2	LOW PRESSURE SAMPLE POINT

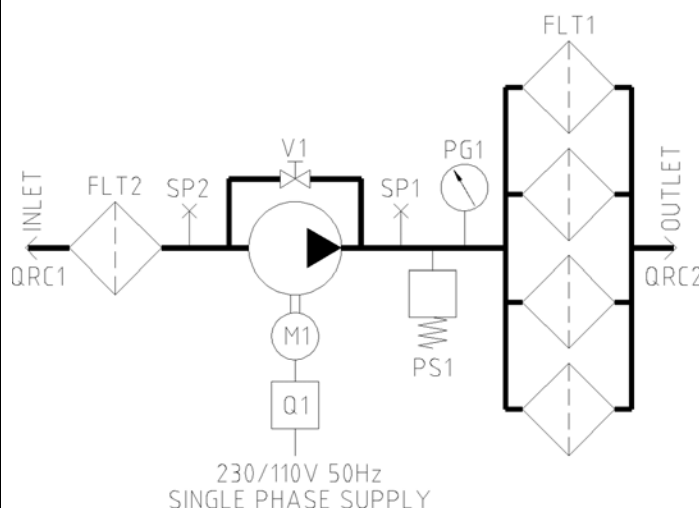

Certificate No: 8445

Registered in England No: 1753106  
 VAT No: 386 0916 27

11.01.05.SS 4S1200EINFO.PUB