



DATA SHEET

6S1500BE

Removes Contaminants

Extends Oil Life

Reduces Component Wear

Removes all Water

Saves Machine Downtime

Reduces Disposal Costs

Simple to Install & Use

Low Maintenance Costs

Built in Sampling Points



Cardev International Ltd

Ripon Way, Harrogate, HG1 2AU
Tel: 01423 522911 Fax: 01423 530043
Email: sales@cardev.co.uk or visit our
website at: www.cardev.co.uk



Cardev International Ltd

Ripon Way, Harrogate, HG1 2AU Tel: 01423 522911 Fax: 01423 530043
 e-mail: sales@cardev.co.uk web: www.cardev.co.uk



Industrial Filtration



Biodegradable Lubricants

6S1500BE - SPECIFICATION				
Electric Motor	VOLTS	110	230	
	Kws	0.37	0.37	
	Amps	8.0	4.0	
	RPM	1425	1425	
	Protection	IP55		
Pump Performance	1500 litres/hour @ 2.6 bar (ISO 46 Hydraulic oil at 40°C) 1600 litres/hr @ 1 bar—transfer rate using valve			
Pump Suction Lift	Self priming to 5.5 metres			
Operating Temperature	10-90°C			
Rig Dimensions	Length	1105 mm		
	Width	595 mm		
	Height	1000 mm		
	(with handle removed)	780 mm		
Rig Weight	107 kg			
Filtration System	6 x SDUFB-C			
Cartridge Type	6 x SDFC—Fitted as standard. Supplied in boxes of 6			
Accessories	6 metres of reinforced 1" hose with quick release couplings Plug to suit voltage (UK only)			
Options	110v, 3-phase and air motors, 45 cm bag-type pre-filter Flow meter and Particle Counter SDFC-P Cartridges for water based fluids			

FLT1	MAIN FILTER (SDU/SDFC)
FLT2	PRE-FILTER
M1	PUMP MOTOR
RV1	PRESSURE RELIEF VALVE
Q1	CONTROL UNIT
PG1	PRESSURE GAUGE
QRC1	INLET QUICK RELEASE COUPLING
QRC2	OUTLET QUICK RELEASE COUPLING
SP1	HIGH PRESSURE SAMPLE POINT
SP2	LOW PRESSURE SAMPLE POINT

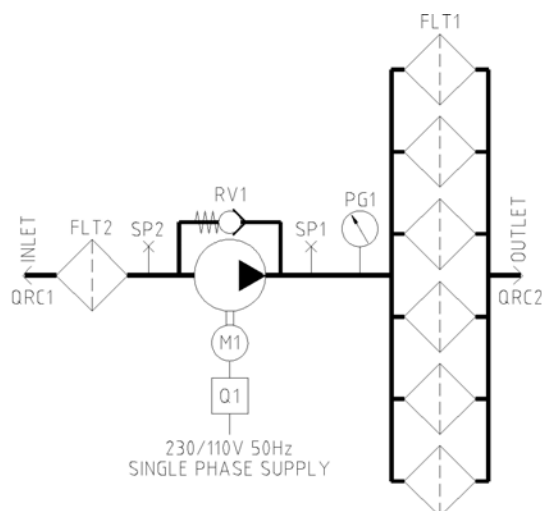

Certificate No: 8445

Registered in England No: 1753106
 VAT No: 386 0916 27

11.01.05.SS 6S1500BEINFO.PUB