

CARDEV

Oil Filtration and Coolant Handling Specialists



2S500B-S

Removes Contaminants

Extends Oil Life

Reduces Component Wear

Removes all Water

Saves Machine Downtime

Reduces Disposal Costs

Simple to Install & Use

Low Maintenance Costs

Built in Sampling Points



Cardev International Ltd

Ripon Way, Harrogate, HG1 2AU
Tel: 01423 522911 Fax: 01423 530043
Email: sales@cardev.co.uk or visit our
website at: www.cardev.co.uk



06.01.05.SS 2S500B-S

2S500B-S



Industrial Filtration



Biodegradable Lubricants

SINGLE PHASE SCHEMATIC

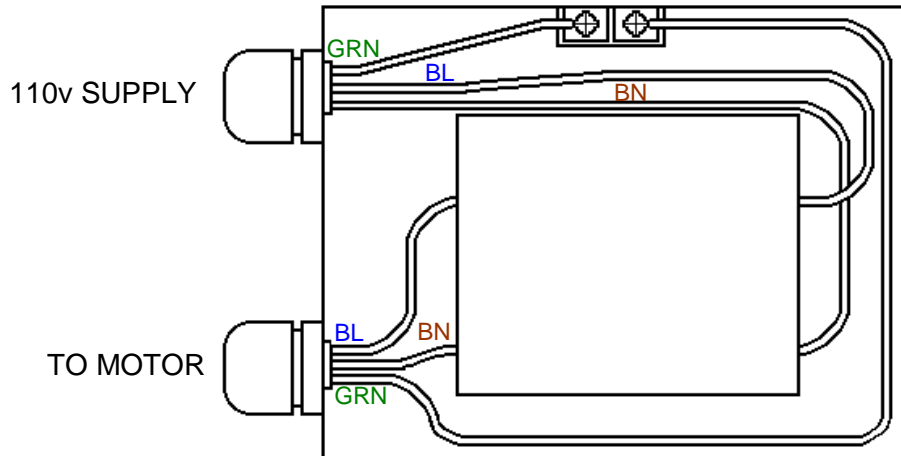
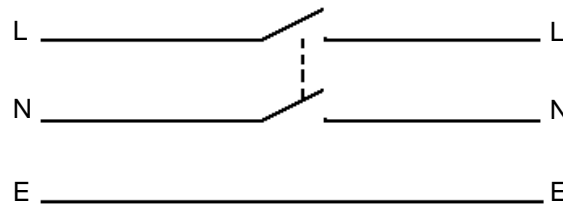

2S 500B-S SPECIFICATION			
Electric Motor	Volts	110	230
	Kws	0.18	0.18
	Amps	5.2	2.3
	RPM	1425	1425
	Protection	IP55	
Pump Performance	500 litres/hour at 2.8 bar (ISO 46 hydraulic oil at 40°C)		
Pump Suction Lift	Self priming to 5.5 metres		
Rig Dimensions	Length	576mm	
	Width	265mm	
	Height	550mm	
Rig Weight	45kg		
Filtration System	2 X SDU H8		
Cartridge Type	2 X SDFC—fitted as standard. Supplied in boxes of 6		
Accessories	6 metres of reinforced 3/4" hose with quick release couplings Plug to suit voltage		
Options	110v motor SDFC-P Cartridges for water based fluids		

2S500B-S

SCHEMATIC



Industrial Filtration



Biodegradable Lubricants

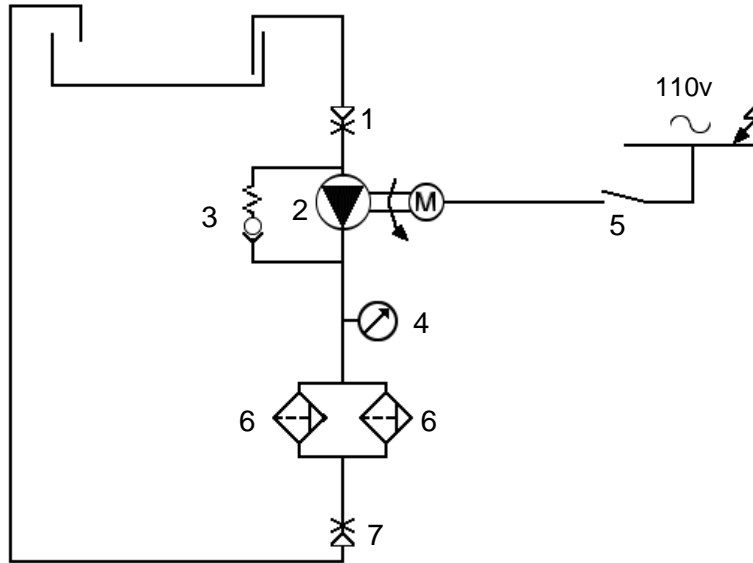

1	INLET QUICK RELEASE COUPLING
2	MOTOR/PUMP
3	PRESSURE CONTROL/DUMP VALVE
4	PRESSURE GAUGE
5	ON/OFF SWITCH
6	CARDEV FILTER 2 x SDU-SDFC
7	OUTLET QUICK RELEASE COUPLING

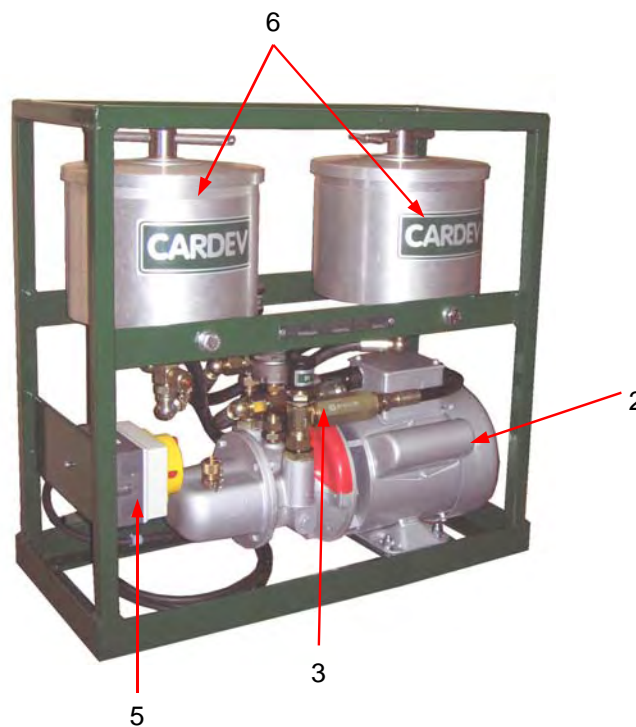



Description

The 2S500B-S Micron Filtration System is a compact free standing off line oil cleaning and filtration system, capable of removing fine dirt particles and totally removing water. Filter cartridges are also available for use on water based fluids

Set up Operation

1. Cut hose to suit IN or OUT requirements
2. Prime pump before use—pour oil down inlet hose.
3. Place hoses in oil tank.

Starting

Turn red knob to start.

Cold Starting

If oil is thick, pressure may rise and the built-in relief valve will open at approximately 4 bar.

Performance Guide

To achieve optimum cleanliness, the contents of each tank should pass through the filter a minimum of 4-5 times.

E.g. a 500 litre tank at 40°C will take approx. 4-5 hours to clean.

Note: The above is a guide only and results will depend on the contamination level in each tank.

Cartridge Change Intervals

The cartridge should normally be changed after 200 hours operation. Where the unit is used continuously on dirty oil or oil contaminated with water, the cartridge may require changing more frequently. Also, if the relief valve is constantly open at approx. 4 bar. Once the operating pressure has been determined (approx. 2.5 –3 bar), a rise of 1 bar indicates the cartridges are becoming blocked.

Cartridge Change Procedure

1. Switch off motor
2. Remove "IN" hose
3. Depress nodule on inlet coupling and run motor for 30 secs. to purge the units of oil.
4. Release lid securing bolt.
5. Remove cartridge by twisting and pulling out with the attached straps.
6. Change the cartridge and replace lid seal.
7. Replace lid and tighten firmly by hand.
8. Check for leaks.
9. Run for 10 mins. and confirm lid bolt secure.

Trouble Shooting

Reduced flow from rig:-

1. Check inlet hose for leaks and blockages.
2. Check hose is below oil but not sucking against floor or wall.
3. Check quick release coupling—remove to clean
4. Check cartridges are not blocked.
5. If none of the above, check pump stator.

Electrical Switch

ON/OFF switch

Protection

1. Built-in 4 bar relief valve.

Action to be taken if motor stops

1. Motor is fitted with thermostatic control. Wait for unit to cool and try again.
2. Check cartridges are not blocked.

Filtration Levels

Through a Cardev filter SDFC, the level of filtration is BS 5540/4, ISO 14/9 and the equivalent NAS 1638 class 5. Water is removed to below 0.05%

Guarantee

The 2S500B-S system carries a 12 month warranty on all parts. Full details are given on the guarantee card attached to the system.

2S500B-S

PUMP/MOTOR



Industrial Filtration



Biodegradable Lubricants

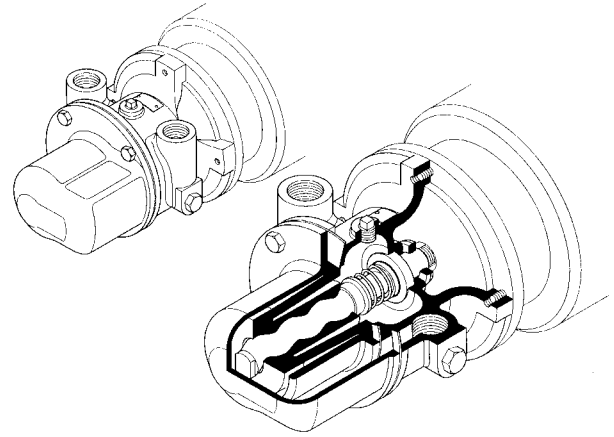
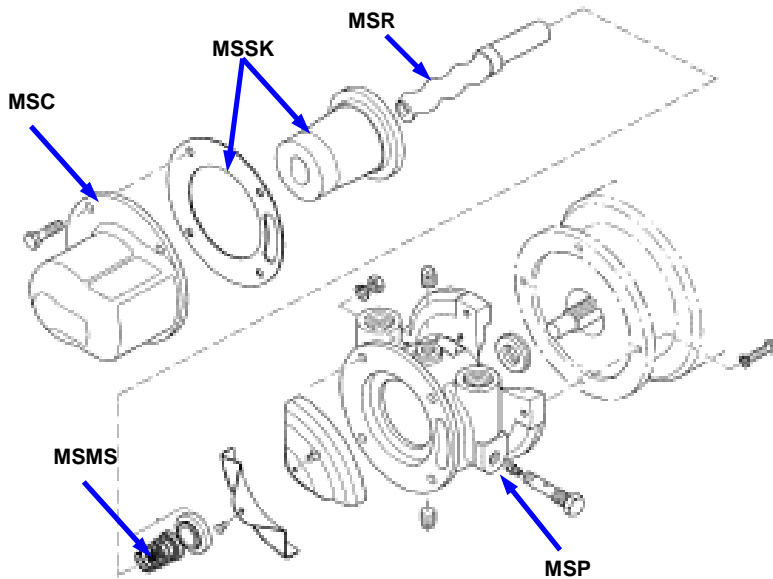

Stator

This is removed by undoing the four nuts and bolts securing the barrel which is then pulled off the body. This exposes the stator which can then be removed from the rotor.

Rotor

This is removed by holding the motor shaft with a spanner on the two flats on the shaft and unscrewing the rotor with the aid of a second spanner on the flats on the end of the rotor. The threads are LEFT HAND and so the rotor should be screwed in a clockwise direction (when looking at the end of the rotor.) Removal of the rotor also releases the mechanical seal and care should be taken not to damage the mating sealing edges.

Seal

If this is disturbed or removed because of damage, when replacing or fitting a new seal, ensure it is correctly assembled before re-fitting into the pump. The rubber seal and stationary seat should be pressed into the body housing and the rotating portion assembled on to the rotor shaft before screwing the rotor back on to the motor shaft which is then locates the mechanical seal with its correct tension.

To Re-Fit

The reverse procedure is used to that of dismantling.

START-UP PROCEDURE

Pumps must be filled with liquid before starting. The initial filling is not for priming purposes, but to provide the necessary lubrication of the stator until the pump primes itself.

When the pump is stopped, sufficient liquid will normally be trapped in the rotor/stator assembly to provide lubrication upon re-starting.

If, however, the pump has been left standing for an appreciable time, moved to a new location, or has been dismantled and re-assembled, it must be refilled with liquid and given a few turns before starting.

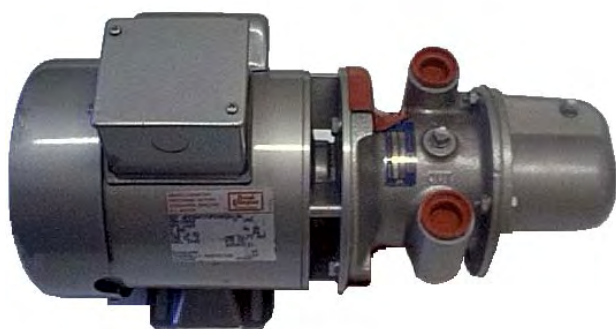

PUMP & MOTOR

MS: 230V

MS: 110V

MOTOR

MSM: 230V

MSM: 110V

CAPACITOR

MSC: 230V

MSC: 110v

2S500B-S

SPARE PARTS LIST



Industrial Filtration



Biodegradable Lubricants



ON/OFF SWITCH (5)
SW500B



DUMP VALVE (3)
DV12 4.0BAR



FLOW METER (OPTION)
FLOWK400

SDUH8

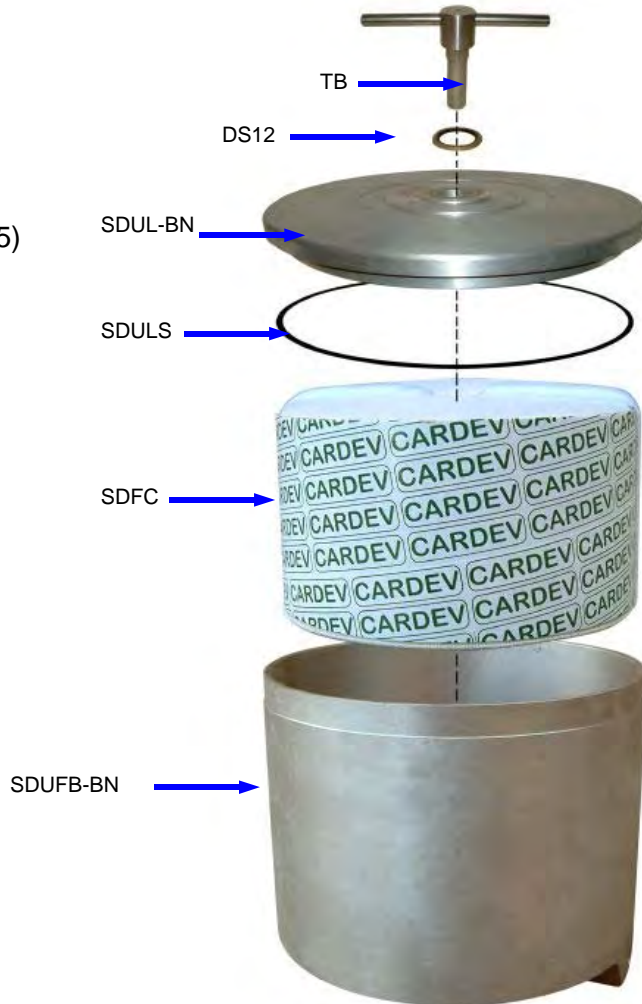

HOSE & COUPLING SET (COMPLETE)
OS2B



QUICK RELEASE COUPLING SET (1,7)
QRS08



PRESSURE GAUGE(4)
PG160F