

CARDEV

Oil Filtration and Coolant Handling Specialists



4S1200BE

Removes Contaminants

Extends Oil Life

Reduces Component Wear

Removes all Water

Saves Machine Downtime

Reduces Disposal Costs

Simple to Install & Use

Low Maintenance Costs

Built in Sampling Points



Cardev International Ltd

Ripon Way, Harrogate, HG1 2AU
Tel: 01423 522911 Fax: 01423 530043
Email: sales@cardev.co.uk or visit our
website at: www.cardev.co.uk



4S1200BE - SPECIFICATION				
Electric Motor	VOLTS	110	230	
	Kws	0.37	0.37	
	Amps	8.0	4.0	
	RPM	1425	1425	
	Protection	IP55		
Pump Performance	1200 litres/hour @ 2.6 bar (ISO 46 Hydraulic oil at 40°C) 1600 litres/hr @ 1 bar—transfer rate using valve			
Pump Suction Lift	Self priming to 5.5 metres			
Operating Temperature	10-90°C			
Rig Dimensions	Length	875mm		
	Width	595mm		
	Height	1000mm		
	(with handle removed)	780mm		
Rig Weight	95kg			
Filtration System	4 x SDUFB-C			
Cartridge Type	4 x SDFC—Fitted as standard. Supplied in boxes of 6			
Accessories	6 metres of reinforced 1" hose with quick release couplings Plug to suit voltage (UK only)			
Options	110v, 3-phase(N) and air motors 45cm bag-type pre-filter Flow meter SDFC-P Cartridges for water based fluids			



Description

The 4S1200BE Micron Filtration System is a compact free standing off line oil cleaning and filtration system, capable of removing fine dirt particles and totally removing water. Filter cartridges are also available for use on water based fluids

Set Up Operation

1. Cut hose to suit IN or OUT requirements.
2. Prime pump before use—put oil down inlet hose.

Starting

Press green button start,.

Cold Starting

If oil is thick, pressure may rise and built in relief valve will open at approximately 4 bar.

Performance Guide

To achieve optimum cleanliness, the contents of each tank should pass through the filter a minimum of 4-5 times.

E.g. a 1200 litre tank at 40°C will take approx. 4-5 hours to clean.

Note: The above is a guide only, and results will depend on the contamination levels in each tank.

Cartridge Change Intervals

The cartridge should normally be changed after 200 hours operation. Where the unit is used continuously on dirty oil or oil contaminated with water, the cartridge may require changing more frequently. Also if the relief valve is constantly open at approx. 4 bar. Once the operating pressure has been determined (approx. 2.5-3 bar) a rise of 1 bar indicates the cartridges are becoming blocked. (See Cold Starting)

Cartridge Change Procedure

1. Switch off motor if not done automatically.
2. Remove "IN" hose.
3. Depress nodule on inlet coupling and run motor for 30 secs. to initially purge the units of oil.
4. Remove lids and extract filter element by twisting and pulling out with the attached straps.
5. Change the cartridge and replace lid seal, ensuring seal is coated in oil prior to seating.
6. Replace lid and tighten manually with lid securing bolt.
7. Clean pre-filter. Ensure sealing ring is correctly located.
8. Run the system for 10 mins., checking that there are no leaks, particularly ensuring that the lid securing bolts have been tightened sufficiently.

Electrical Switch

Green Button: Start
 Red Button: Stop
 Red Light: Power connected
 Green Light: Pump & motor running

Protection

1. Overload relay.
2. Built in 4 bar relief valve.

Trouble Shooting

Reduced flow from rig:-

- i. Check inlet hose for leaks and blockages.
- ii. Check hose is below oil but not sucking against floor or wall.
- iii. Clean pre-filter and check "o" ring is secure.
- iv. Check quick release coupling—remove to clean
- v. Check cartridges are not blocked.
- vi. If none of the above, check pump stator.

Contamination Monitoring

The 4S1200BE is fitted with 2 sample points for use with portable PMB 4000 particle counter or similar device. Connect the appropriate pipes.

Red — high pressure in; yellow — low pressure return

This will enable an ISO rating / particle count to be taken whilst the system is in operation.

Oil Sampling

To take an oil sample, connect only to the red sample point - wait for a steady flow before sampling.

Filtration Levels

Through a CARDEV filter SDFC, the level of filtration is ISO 4406, ISO<13/9 and the equivalent NAS 1638 class 4/5. Water is removed to below 0.05%

Guarantee

The 4S1200BE system carries a 12 month warranty on all parts. Full details are given on the guarantee card attached to the system.

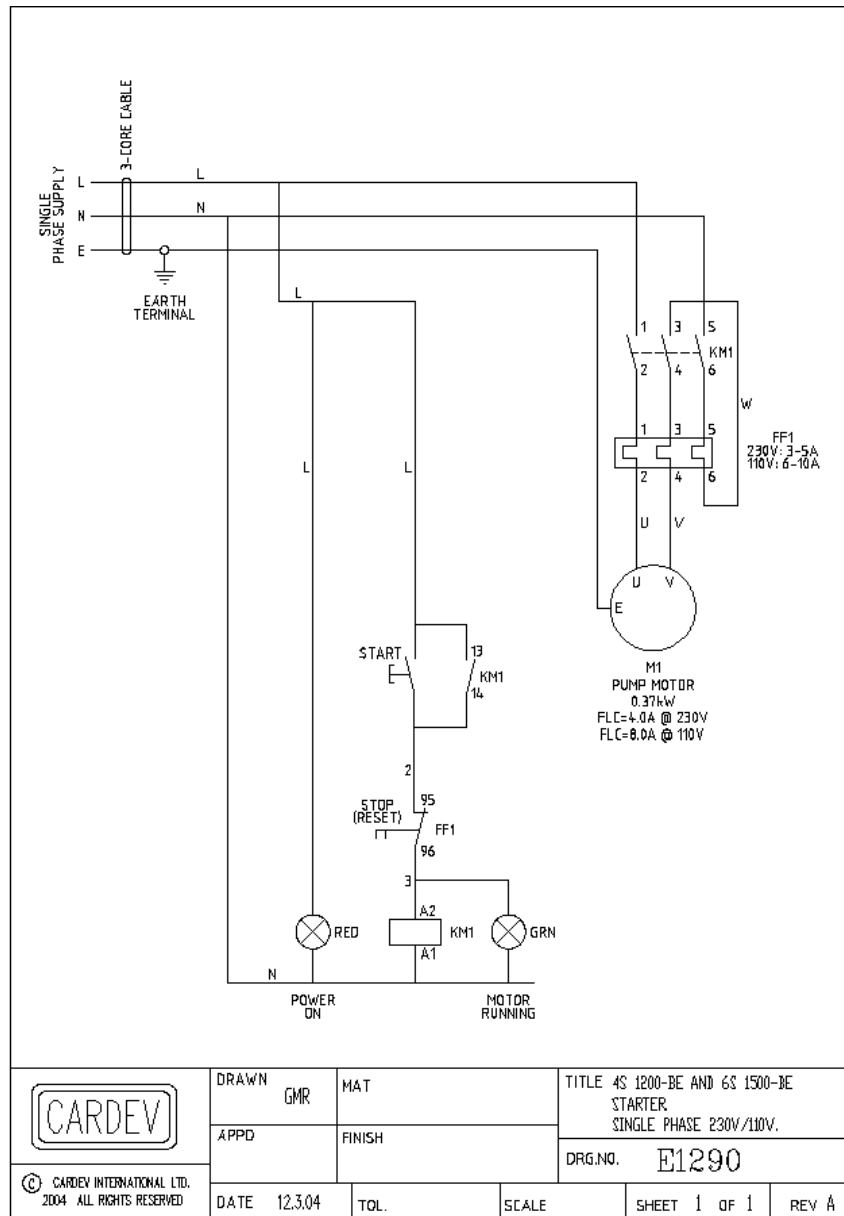

	DRAWN	GMR	MAT	TITLE 4S 1200-BE AND 6S 1500-BE STARTER		
	APPD		FINISH	SINGLE PHASE 230V/110V.		
© CARDEV INTERNATIONAL LTD. 2004 ALL RIGHTS RESERVED	DATE 12.3.04		TOL.	SCALE	SHEET 1 OF 1	REV A
				DRG.NO. E1290		

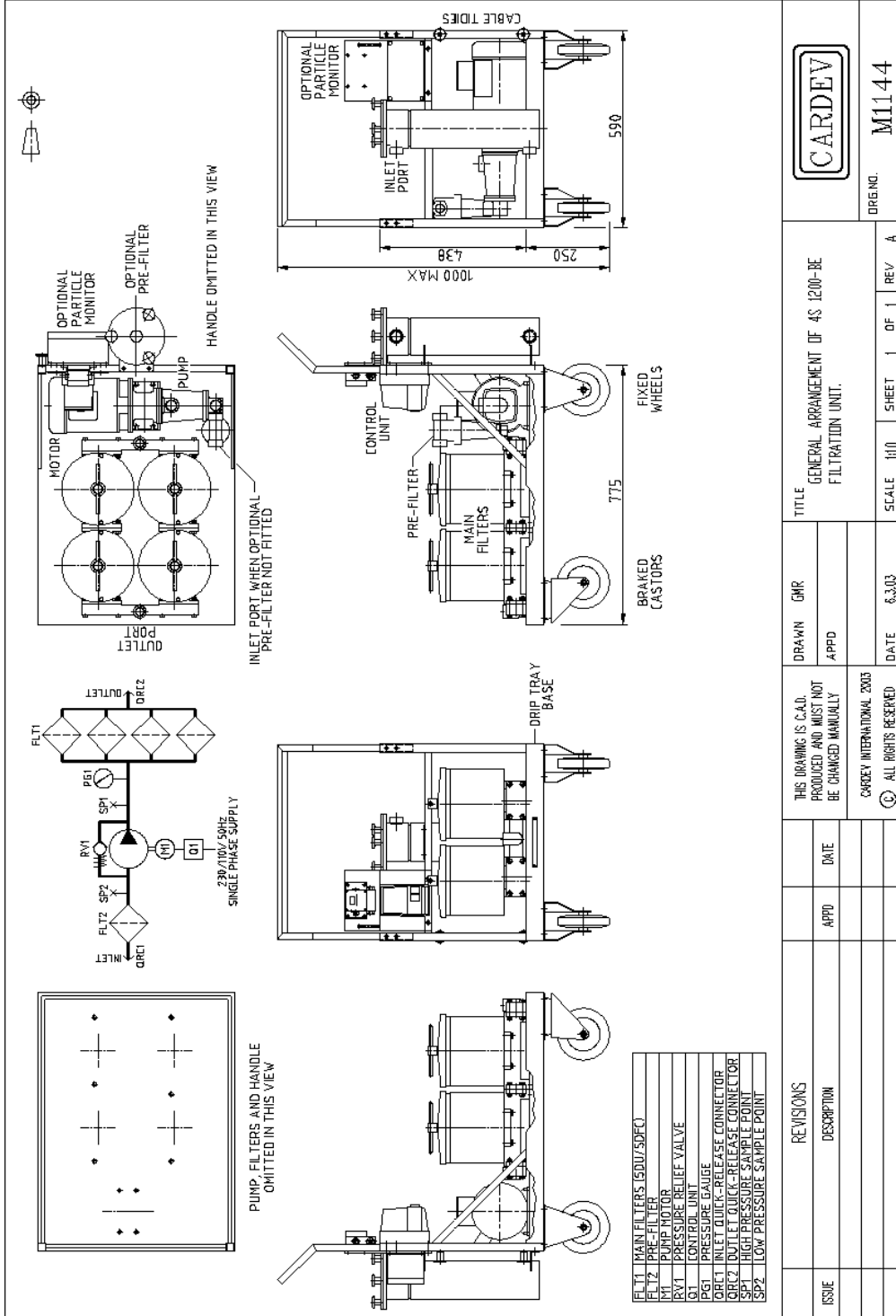

4S1200BE

MOTOR / PUMP



Industrial Filtration



Biodegradable Lubricants

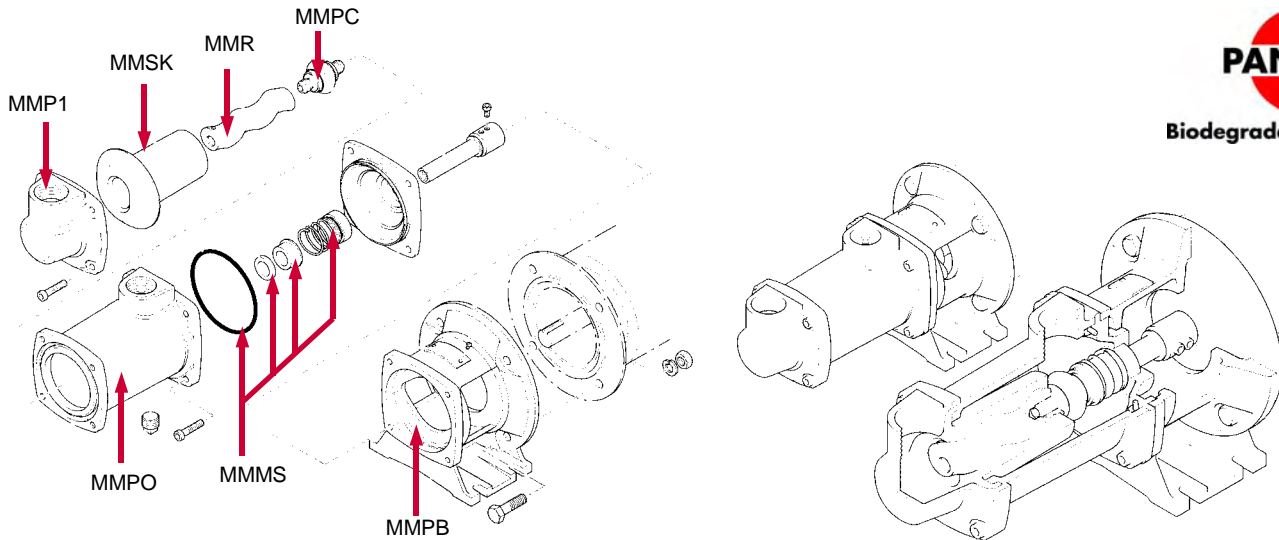

Maintenance

Under normal working conditions, this range of pumps should require little attention, but when required the following procedure can be adapted.

Stator

This is removed by undoing the four caphead screws and removing the end cover. This exposes the stator which can then be pulled off the end of the rotor. This can be helped by inserting the blade of a screwdriver under stator flange to lift it away from the barrel.

Rotor and Coupling

Having removed the end cover and stator, undo the four caphead screws securing the barrel to the body. The barrel can now be withdrawn from the body to expose the rotor, coupling and seal housing for disassembly.

Motorised Pump

Disassembly of the rotor and coupling is perhaps best effected by unscrewing the shaft extension to the motor shaft. The whole assembly can then be withdrawn from the pump (Rotor, coupling, seal housing and shaft extension) to facilitate the ease of dismantling. By holding the rotor in the soft jaws of a vice, the coupling/shaft extension can be unscrewed (standard right hand threads) to separate the individual components for replacement if necessary, taking particular care not to damage the seal faces.

Electric Motor

When fitting a replacement motor to an assembled pump, ensure the motor shaft and flange are clean and free from burrs. The pump shaft extension should be pressed home on to the motor shaft before tightening the locking capscrews down into the key slot location.

Re-fitting

This should be done in exactly the reverse order to the dismantling sequence, always ensuring parts are clean and free from burrs and other defects.

START-UP PROCEDURE

Pumps must be filled with liquid before starting. The initial filling is not for priming purposes, but to provide the necessary lubrication of the stator until the pump primes itself.

When the pump is stopped, sufficient liquid will normally be trapped in the rotor/stator assembly to provide lubrication upon re-starting. If, however, the pump has been left standing for an appreciable time, moved to a new location, or has been dismantled and re-assembled, it must be refilled with liquid and given a few turns before starting.

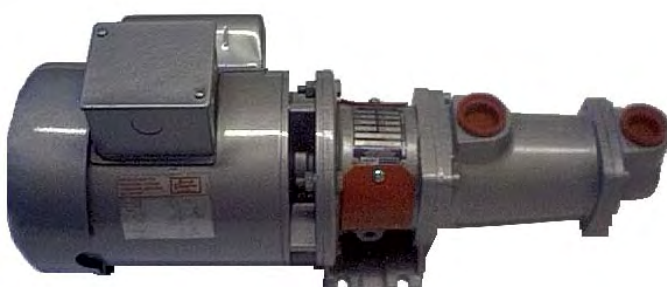

PUMP & MOTOR

MM110V
MM230V

MOTOR

MMM110V
MMM230V

CAPACITOR

MMC110V
MMC230V

4S1200BE

PARTS LIST



Industrial Filtration



Biodegradable Lubricants



ELECTRICAL CONTROL ASSEMBLY (COMPLETE)
SW250



FLOW METER (OPTION)
FLOWK400



PRESSURE GAUGE
PG160F



CONTACTOR BG0910A
CON1B:110V
CON2B 230V/400

SDUL-BN

SDU-H8



TB

DBS12

SDULS

SDFC

SDUFB-C

SDUFB-M



OVERLOAD RELAY
TOR5:230V 3-5A
TOR10:110V 6-10A



QUICK RELEASE COUPLING
QRS12



WHEEL
WFC6

BRAKED WHEEL
WSWB6



DUMP-VALVE
DV12 4.0BAR



FLANGE 'O' RING
SDUFB-CO



LONG FLANGE
SDUFB-CLF



LARGE PREFILTER SEAL
PFG09LS



LARGE PREFILTER STRAINER
GG09



LARGE PREFILTER (OPTIONAL)
PFG09SS



HOSE WITH FITTINGS COMPLETE
OST4/6DRS



PREFILTER BAGS
G09NM50 ETC, G09P10 ETC
VARIOUS MICRON AVAILABLE



PFS5

PFG

PREFILTER
PF34NPT



PREFILTER KNOBS (SET OF 3)
PFG09LIDKNOB