

CARDEV

Oil Filtration and Coolant Handling Specialists



4S1200E AIR

Removes Contaminants

Extends Oil Life

Reduces Component Wear

Removes all Water

Saves Machine Downtime

Reduces Disposal Costs

Simple to Install & Use

Low Maintenance Costs

Built in Sampling Points



AIR OPERATED

Cardev International Ltd

Ripon Way, Harrogate, HG1 2AU
Tel: 01423 522911 Fax: 01423 530043
Email: sales@cardev.co.uk or visit our
website at: www.cardev.co.uk



4S1200E AIR



Industrial Filtration



Biodegradable Lubricants

4S1200E-AIR - SPECIFICATION		
Pump Performance	1200 litres/hour @ 2.6 bar (ISO 46 Hydraulic oil at 40°C) 1600 litres/hr @ 1 bar—transfer rate using valve	
Pump Suction Lift	Self priming to 5.5 metres	
Pump Motor	0.75 kW equivalent air motor 1500 rpm flange mounted Max. air consumption 45 cfm/1.27m ³ /min	
Operating Temperature	10-90°C	
Dimensions	Length	950 mm
	Width	595 mm
	Height	1000 mm
	(with handle removed)	780 mm
Weight	106 kg	
Filtration System	4 x SDUFB-C	
Cartridge Type	4 x SDFC—Fitted as standard. Supplied in boxes of 6	
Accessories	6 metres of reinforced 1" hose with quick release couplings	
Options	110V,230V and 3-Phase 45cm bag-type pre-filter / Flow Meter Flow meter, SDFC-P Cartridges for water based fluids	

4S1200E AIR



Industrial Filtration



Biodegradable Lubricants

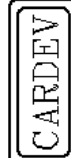
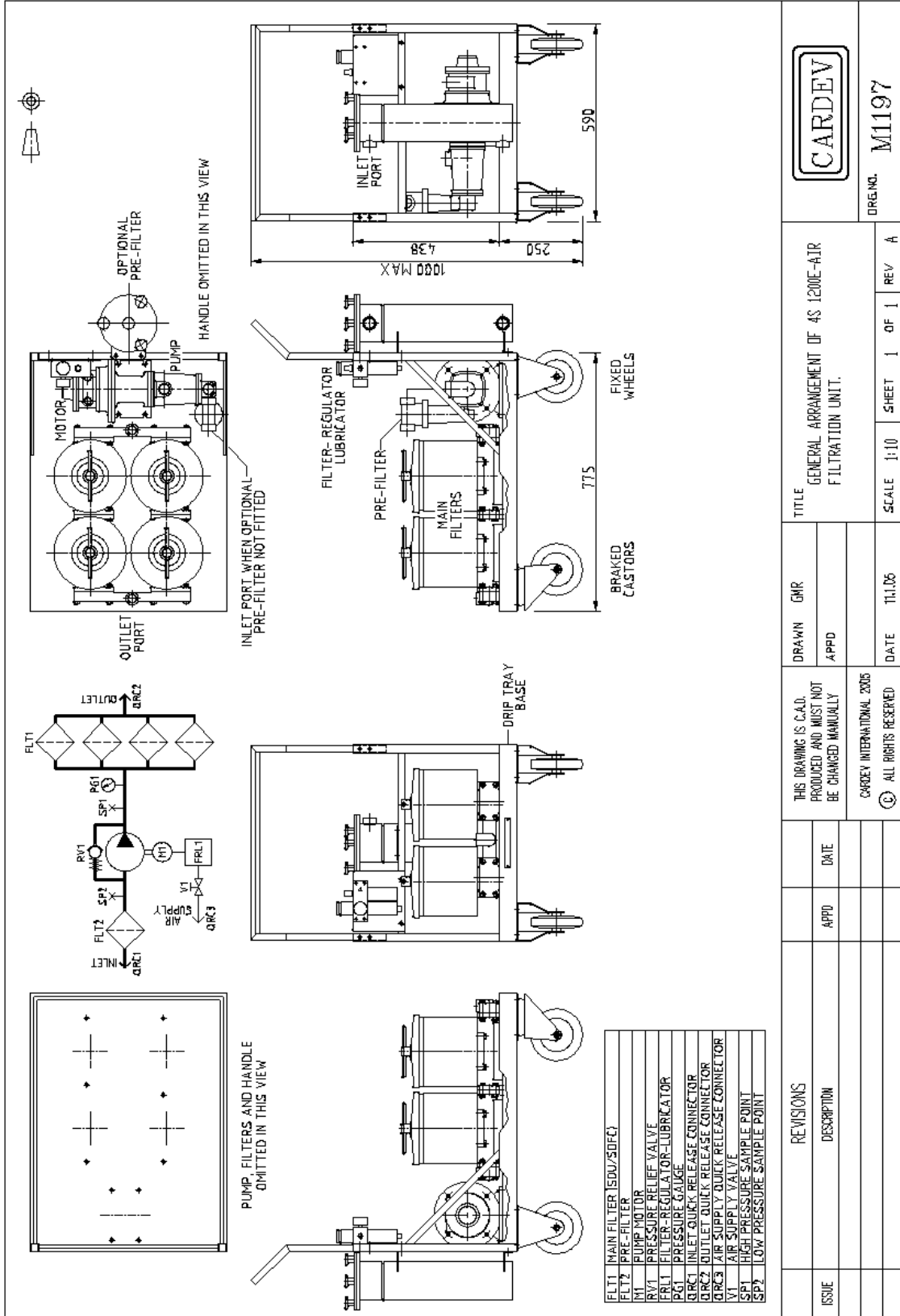

TITLE
GENERAL ARRANGEMENT OF 4S 1200E-AIR
FILTRATION UNIT.

DRAWN
GMR
APPD

THIS DRAWING IS C.A.D.
PRODUCED AND MUST NOT
BE CHANGED MANUALLY
CARDEV INTERNATIONAL 2005
© ALL RIGHTS RESERVED

DATE
11.10.06

SCALE
1:10

SHEET
1 OF 1

REV
A

DWG. NO.
M1197

4S1200E AIR



Industrial Filtration



Biodegradable Lubricants

Description

The 4S1200E AIR Micron Filtration System is a compact free standing off line oil cleaning and filtration system, capable of removing fine dirt particles and totally removing water. Filter cartridges are also available for use on water based fluids

Set Up Operation

1. Cut hose to suit IN or OUT requirements.
2. Insert in oil.
3. Prime pump before use—pour oil down inlet hose.
4. Set the air pressure on the regulator to 6-7 bar .
5. Open the air inlet valve.
6. The air should be controlled by the regulator to produce a normal operating pressure of 2.5 bar as indicated on the filter pressure gauge.

Starting the System

To start the system, the air supply valve should be opened.

Performance Guide

To achieve optimum cleanliness, the contents of each tank should pass through the filter a minimum of 4-5 times.

E.g. a 1200 litre tank at 40°C will take approximately 4-5 hours to clean.

Note: The above is a guide only, and results will depend on the contamination level in each tank.

Cartridge Change Intervals

- When oil pressure is 1.5 Bar above normal
- When the motor has stalled
- 200 hours or monthly

Cartridge Change Procedure

1. Switch off the air supply.
2. Remove the INLET hose.
3. Depress the centre of the inlet coupling and re-start the pump for 30 seconds to purge the filter units of oil.
4. Release lid securing nuts.
5. Remove cartridges using the attached straps.
6. Change the cartridges and replace the lid seal.
7. Replace lids and tighten firmly by hand.
8. Re-start the pump and check the filters for leaks.
9. Run for 10 mins. and confirm lid bolts are secure.

N.B. WHEN REMOVING THE FILTER LID ENSURE THAT THE AIR SUPPLY IS TURNED OFF, PREFERABLY DISCONNECTED, AS THE PUMP MAY BE IN A STALLED CONDITION WITH THE AIR SUPPLY ON.

Cleaning the Pre-filter

All systems are fitted with a 500 micron pre-filter as standard. the pre-filter should be cleaned at each cartridge change.

Transfer Pump Action

To use the system as a transfer pump - without filtration - remove the hose coupling from the filter outlet adaptor and re-connect it to the coupling on the pump outlet.

Protection

The pump is self protecting and in the case of a blocked filter, the pump will stall.

System Maintenance

The regulator air filter is fitted with an automatic drain but a periodic visual inspection should be carried out in accordance with normal maintenance procedures. The lubricator should be topped up as required and checked for operation through the sight glass.

TROUBLE SHOOTING

System pumps slowly

- a. Check hose is below oil but not sucking against the floor or wall of tank.
- b. Clean pre-filter and check "o" ring seal is secure.
- c. Check inlet hose for leaks & blockages.
- d. Check quick release coupling—remove to clean.
- e. Ensure cartridge has been changed.
- f. If none of the above check pump.

Contamination Monitoring

The 4S1200E Air is fitted with 2 sample points for use with portable UCC CM20 particle counter or similar device. Connect the appropriate pipes:

RED - high pressure in
YELLOW - low pressure return

This will enable an ISO rating/particle count to be taken whilst the system is in operation.

Oil Sampling

To take an oil sample, connect only to the red sample point—wait for a steady flow before sampling.

Filtration Levels

Through a CARDEV filter SDFC, the level of filtration is ISO4406, ISO <13/9 and the equivalent NAS 1638 class 4/5. Water is removed to below 0.05%

Guarantee

The 4S1200E Air system carries a 12 month warranty on all parts. Full details are given on the guarantee card attached to the system.

4S1200E AIR

PUMP / MOTOR



Industrial Filtration



Biodegradable Lubricants

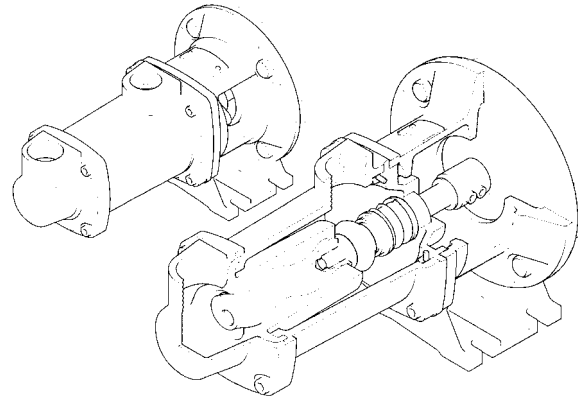
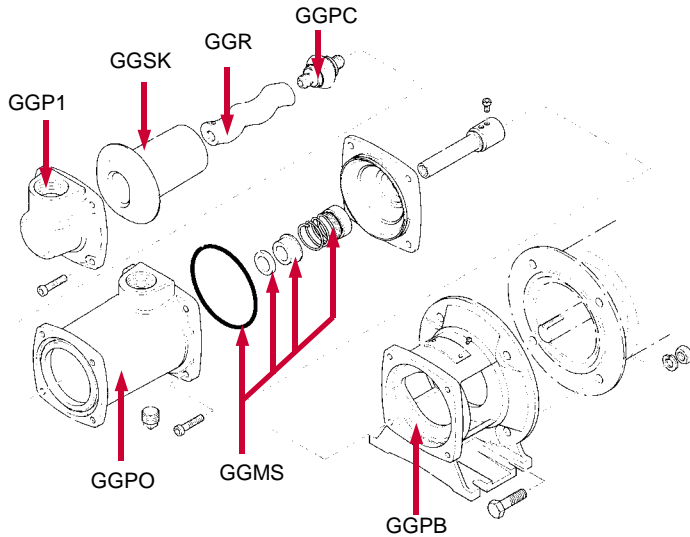

Maintenance

Under normal working conditions, this range of pumps should require little attention, but when required the following procedure can be adopted.

Stator

This is removed by undoing the four caphead screws and removing the end cover. This exposes the stator which can then be pulled off the end of the rotor. This can be helped by inserting the blade of a screwdriver under stator flange to lift it away from the barrel.

Rotor and Coupling

Having removed the end cover and stator, undo the four caphead screws securing the barrel to the body. The barrel can now be withdrawn from the body to expose the rotor, coupling and seal housing for disassembly.

Motorised Pump

Disassembly of the rotor and coupling is perhaps best effected by unscrewing the shaft extension to the motor shaft. The whole assembly can then be withdrawn from the pump (Rotor, coupling, seal housing and shaft extension) to facilitate the ease of dismantling. By holding the rotor in the soft jaws of a vice, the coupling/shaft extension can be unscrewed (standard right hand threads) to separate the individual components for replacement if necessary, taking particular care not to damage the seal faces.

Air Motor

When fitting a replacement motor to an assembled pump, ensure the motor shaft and flange are clean and free from burrs. The pump shaft extension should be pressed home on to the motor shaft before tightening the locking capscrews down into the key slot location.

Re-fitting

This should be done in exactly the reverse order to the dismantling sequence, always ensuring parts are clean and free from burrs and other defects.

START-UP PROCEDURE

Pumps must be filled with liquid before starting. The initial filling is not for priming purposes, but to provide the necessary lubrication of the stator until the pump primes itself.

When the pump is stopped, sufficient liquid will normally be trapped in the rotor/stator assembly to provide lubrication upon re-starting. If, however, the pump has been left standing for an appreciable time, moved to a new location, or has been dismantled and re-assembled, it must be refilled with liquid and given a few turns before starting.

PUMP MOTOR ASSEMBLY

MOTOR
COMPLETE WITH SILENCER
AIRMOT1/6

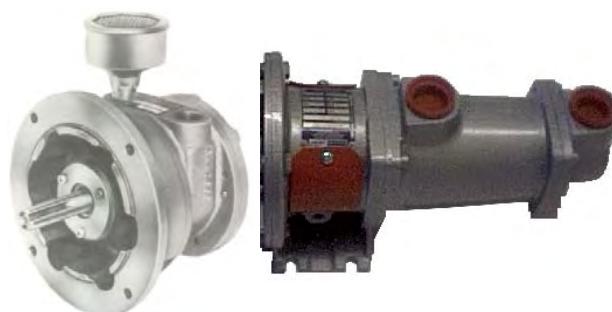

PUMP

4S1200E AIR

SPARE PARTS LIST



Industrial Filtration



Biodegradable Lubricants



AIR REGULATOR
AIRREG4/6



FLOW METER
(OPTION)
FLOWK400



FLANGE 'O' RING
SDUFB-CO



HOSE & COUPLING SET
(COMPLETE)
OST4/6DRS

SDUH8

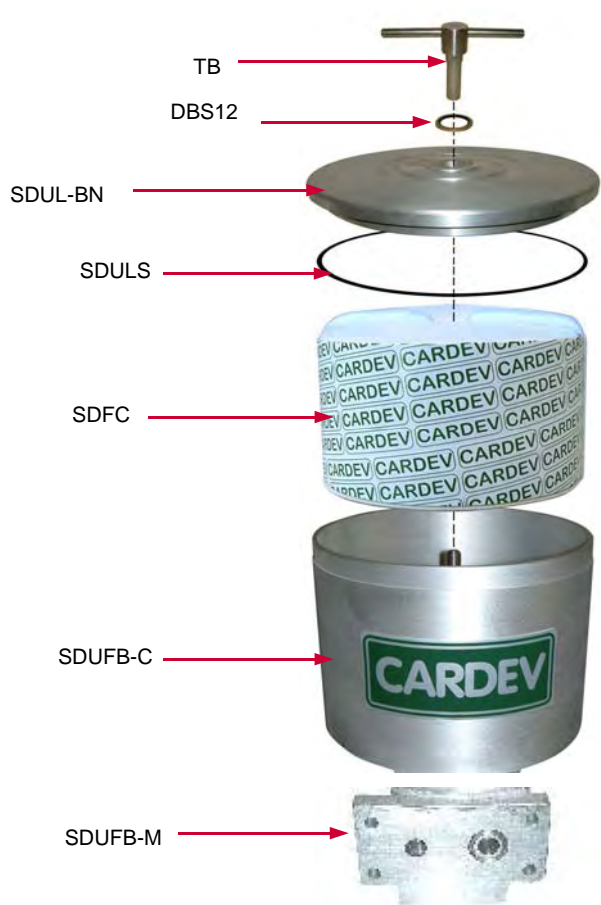

QUICK RELEASE
COUPLING SET
QRS12



FIXED WHEEL
WFC6



BRAKED WHEEL
WSW6



PRE-FILTER BAGS
G09NM50etc
G09P10etc
VARIOUS MICRON
AVAILABLE



LONG FLANGE
SDUFB-CLF



PRE-FILTER SEAL
PFG09LS



PRE-FILTER KNOBS
(SET OF 3)
PFG09LIDKNOB



PFS5

PFG

PRE-FILTER
PF34NPT



PRE-FILTER
STRAINER
GG09

